

Machine Learning

con  —

Evento  en el Nordeste”

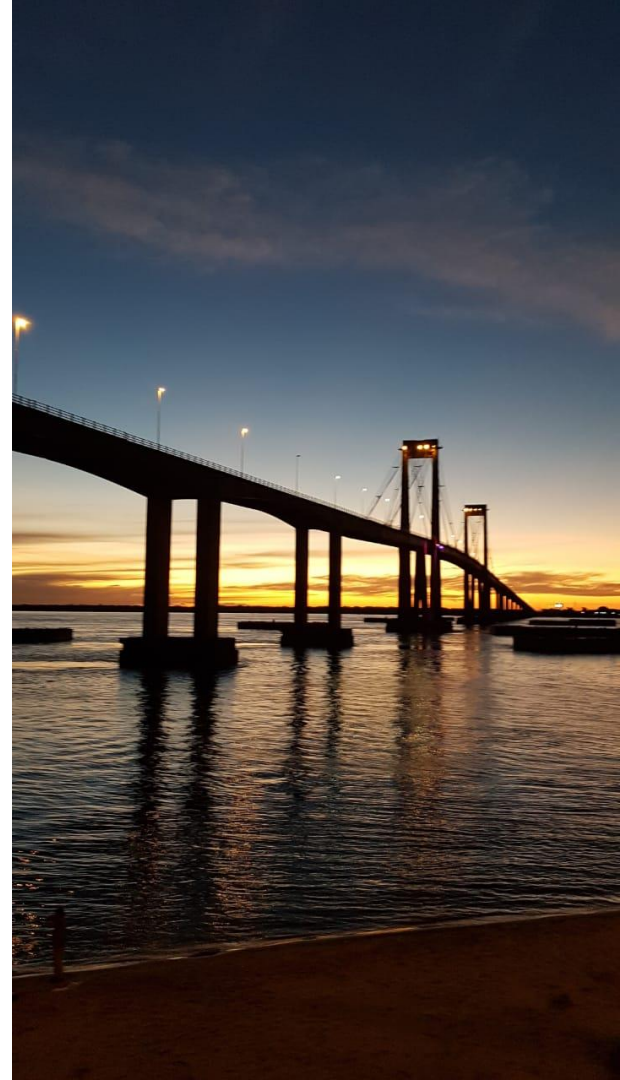

Quien soy



Roxana Noelia Villafañe

(Lic Química)

Dr. Recursos Naturales

Postdoc LEMyP



@data_datum



I Q U I B A - N E A

Machine Learning & IA

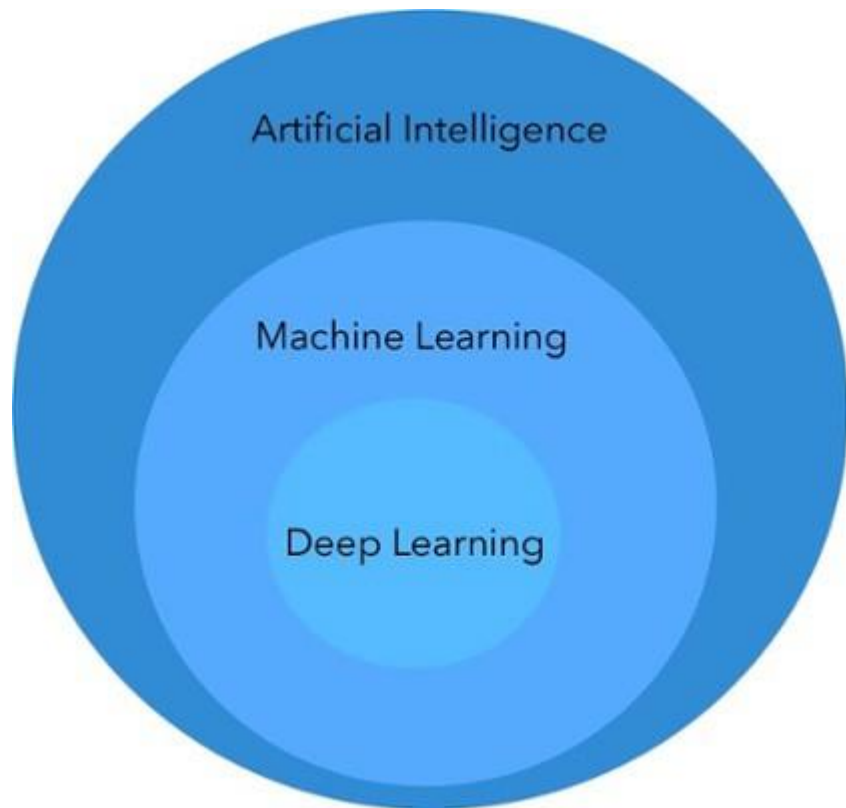

Aprendizaje Supervisado

Aprendizaje No Supervisado

Aprendizaje Reforzado

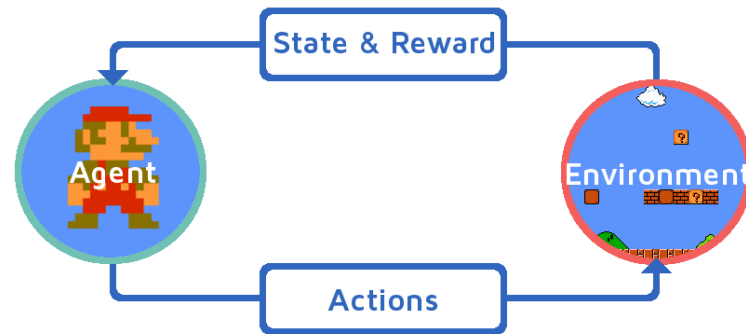

Machine Learning



- ML is about inferring knowledge from observations or experiences, subject to the physical laws of the world.
- ML is also about using this knowledge to guide observation and hypothesis testing.
- ML is about creating knowledge, using the present knowledge, to solve a large diversity of novel problems.



Nando de Freitas

Deep Learning



Deep learning

Yann LeCun^{1,2}, Yoshua Bengio³ & Geoffrey Hinton^{4,5}

Deep learning allows computational models that are composed of multiple processing layers to learn representations of data with multiple levels of abstraction. These methods have dramatically improved the state-of-the-art in speech recognition, visual object recognition, object detection and many other domains such as drug discovery and genomics. Deep learning discovers intricate structure in large data sets by using the backpropagation algorithm to indicate how a machine should change its internal parameters that are used to compute the representation in each layer from the representation in the previous layer. Deep convolutional nets have brought about breakthroughs in processing images, video, speech and audio, whereas recurrent nets have shone light on sequential data such as text and speech.

LeCun, Y., Bengio, Y., Hinton, G. Deep Learning (2015) Nature

Representación



What can be represented

What can be learned

What can be learned practically

What can be learned efficiently

Supervised Unsupervised Reinforcement Learning

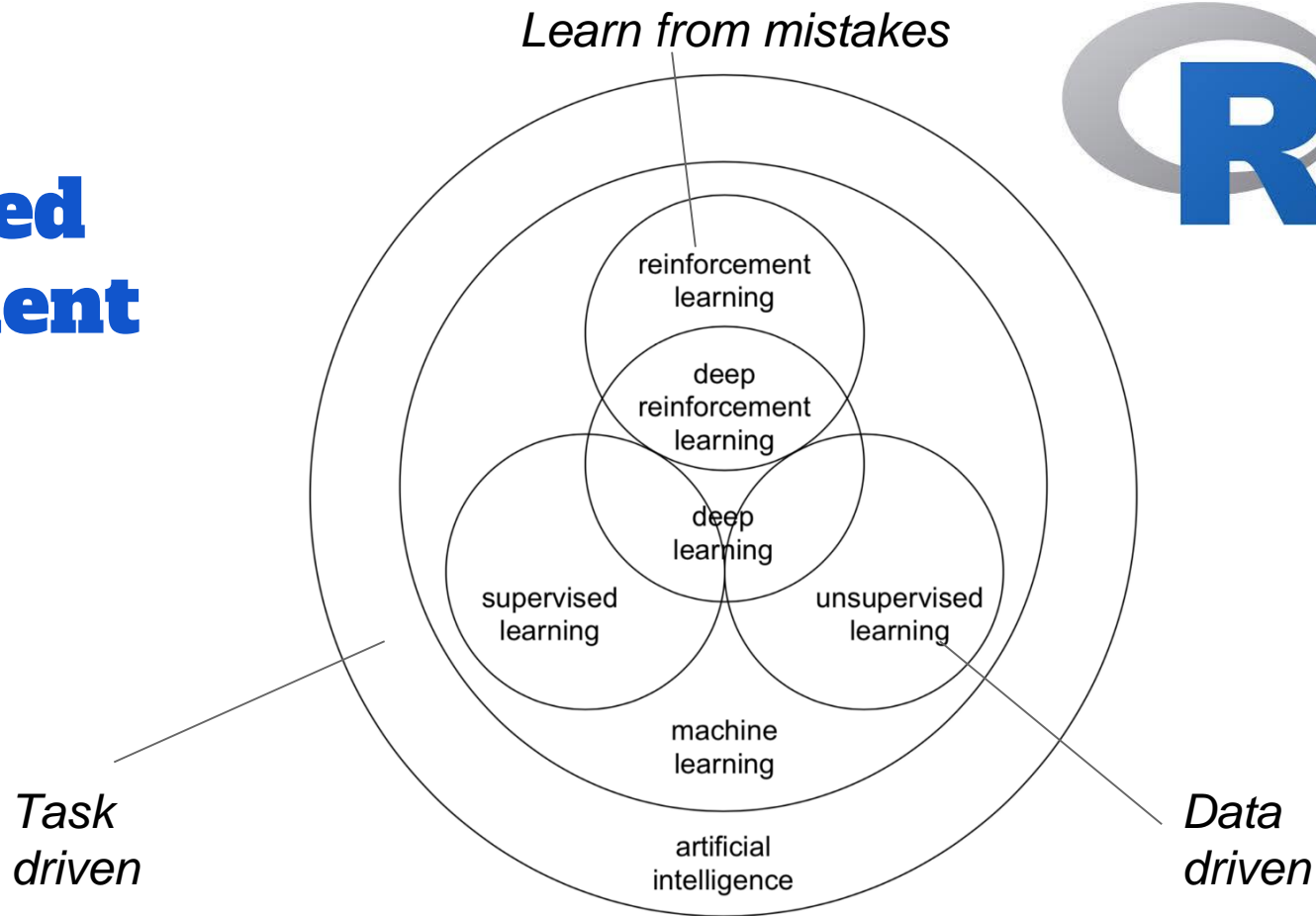



Modelos Discriminativos / Generativos

Discriminative

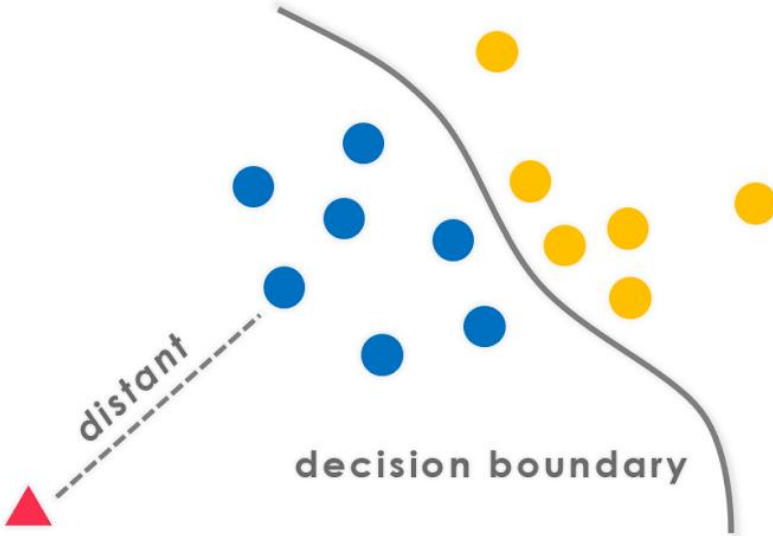

Generative

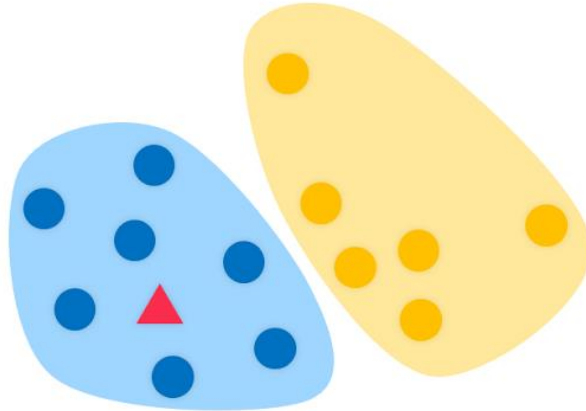



Algunas arquitecturas importantes

Convolutional Neural Networks

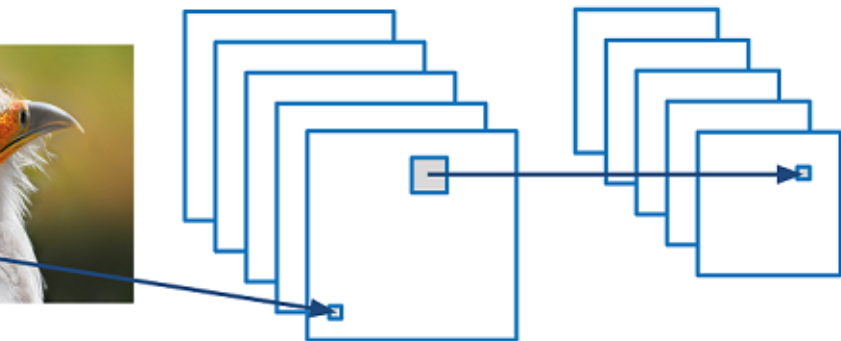

convolution +
nonlinearity

max pooling

convolution + pooling layers

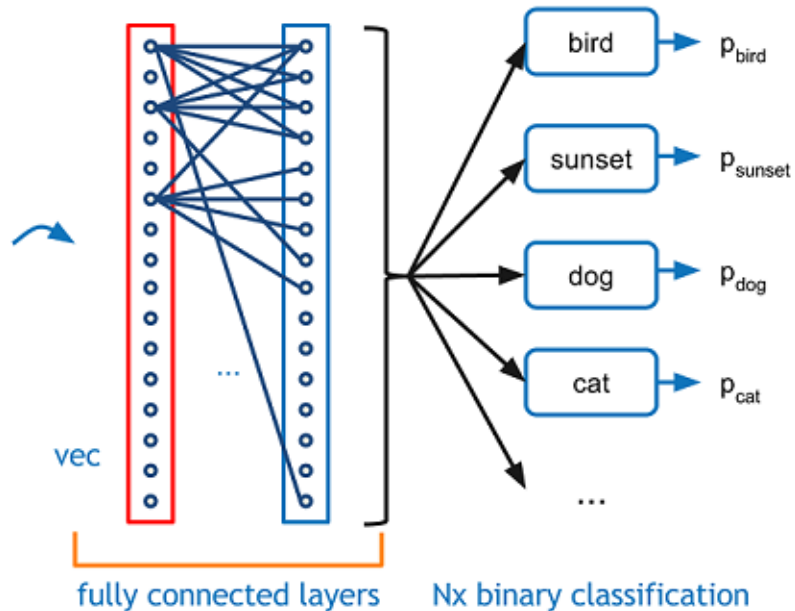

vec

fully connected layers

Nx binary classification

Recurrent Neural Networks

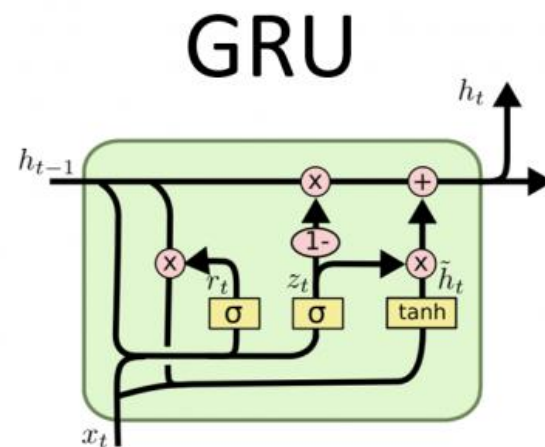
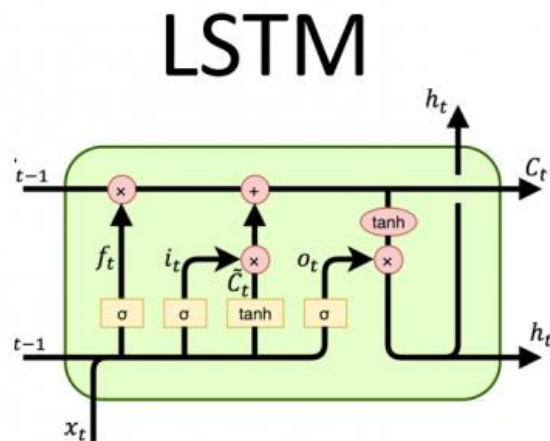
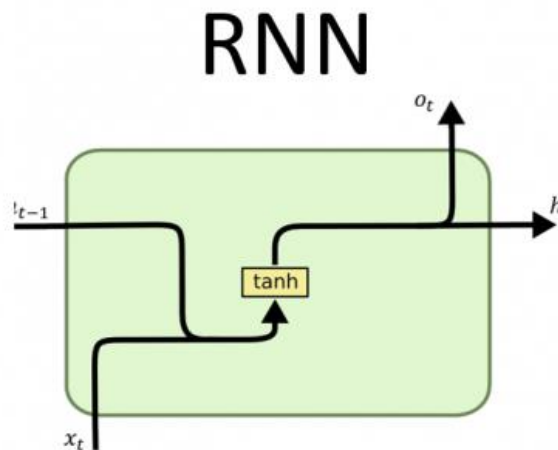

Autoencoders



Input image

Reconstructed image

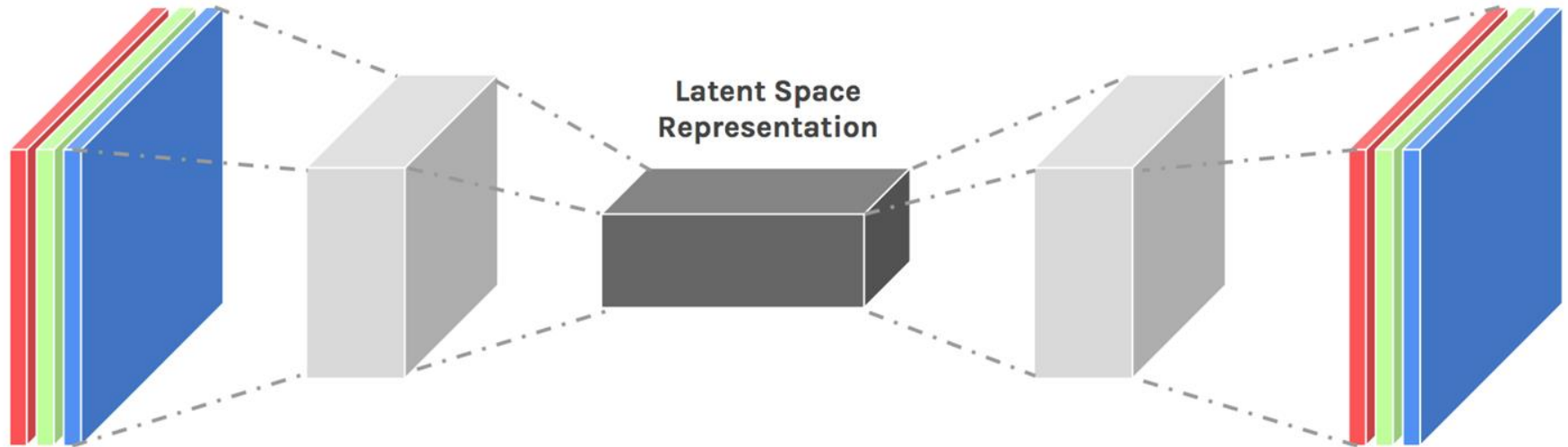

Autoencoders

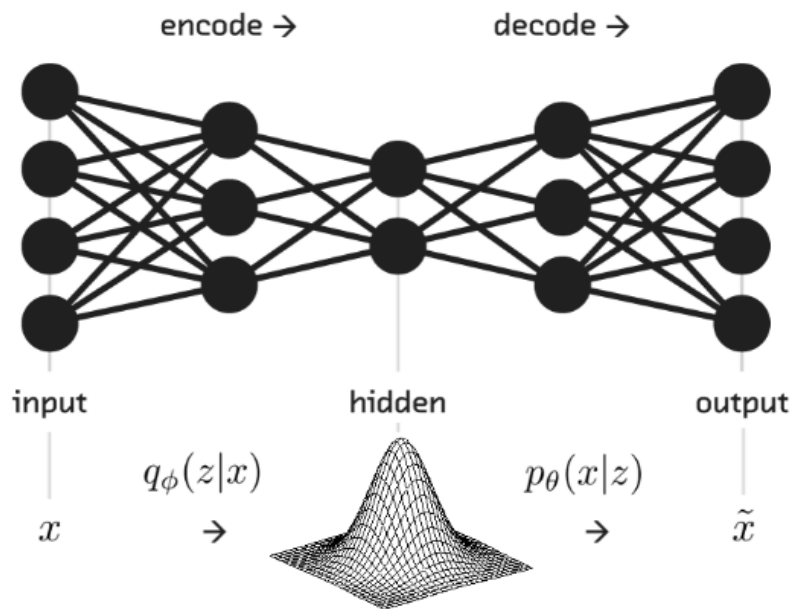
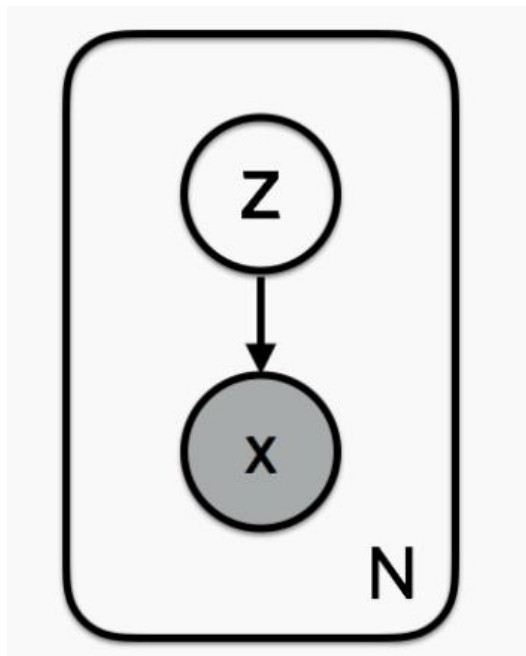

Generative Adversarial Networks (GANs)

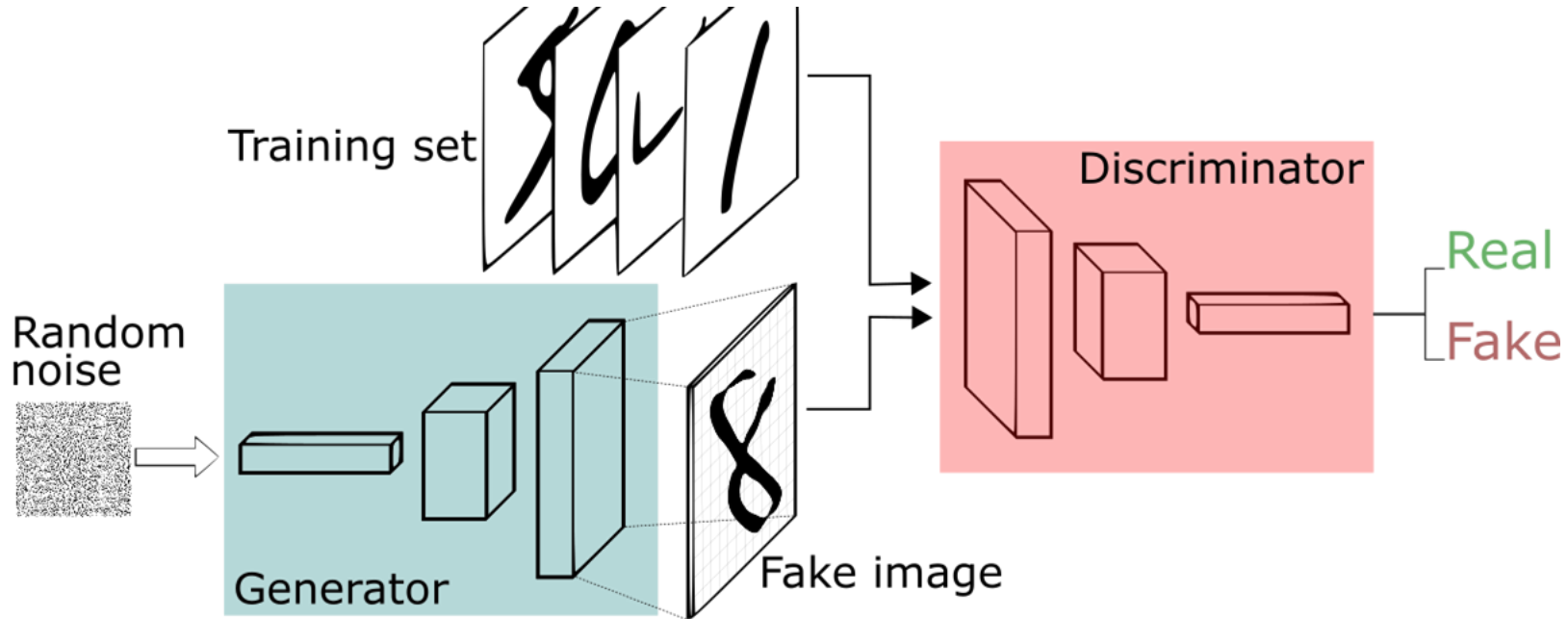

Aplicación: <https://thispersondoesnotexist.com/>

Reinforcement Learning



Reinforcement learning is learning what to do—how to map situations to actions—so as to maximize a numerical reward signal. The learner is not told which actions to take, but instead must discover which actions yield the most reward by trying them.

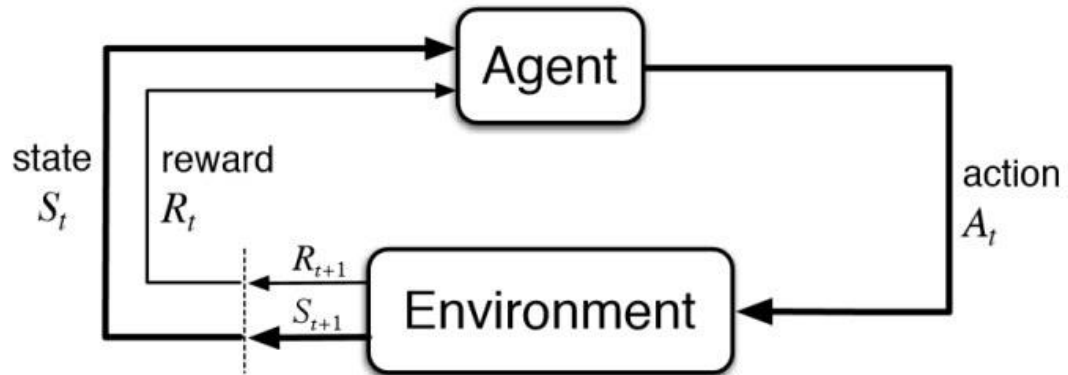

ML con R

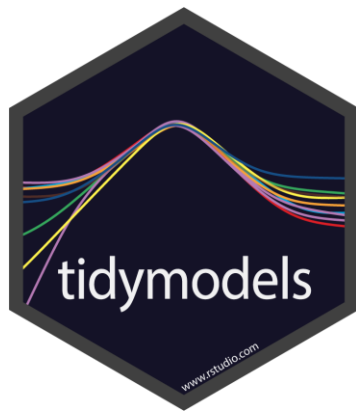

+



Libros y recomendaciones

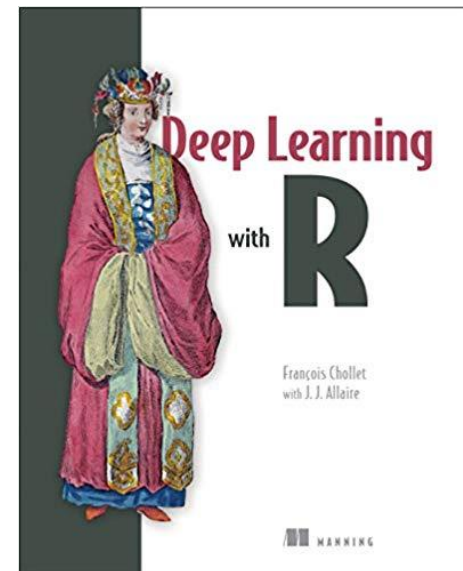
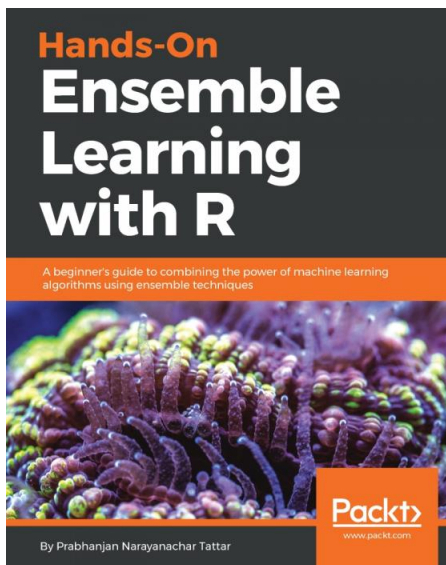
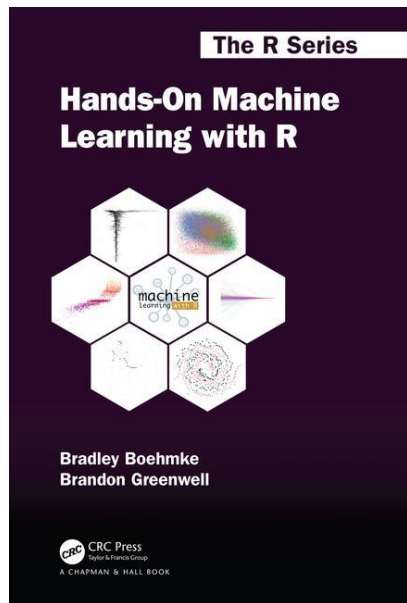
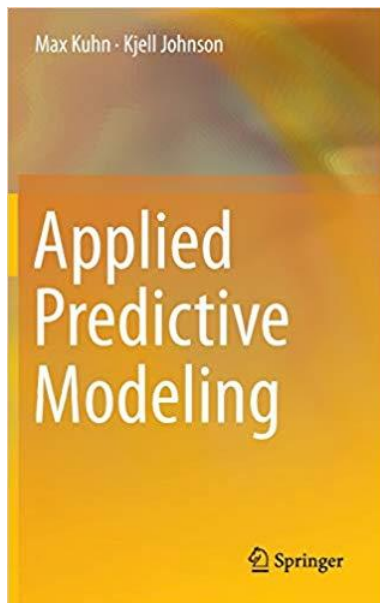

Cursos online

coursera

edX



fast.ai

¿Qué es khipu?



Antiguo sistema para contar de los pueblos originarios de los Andes.

Khipu.ai 2019



- Reunión de investigadores y gente de industria que se dedica a la inteligencia artificial en LATAM.
- Realizado en Montevideo, Uruguay. En la Universidad de la República (UdelaR)
- Asistencia de aproximadamente 200-250 personas.
- Presencia de referentes internacionales en el tema de inteligencia artificial como Nando de Freitas, Oriol Vinyals, Chelsea Finn.
- Charlas técnicas como ser: Redes convolucionales, redes recurrentes, modelos generativos, generalidades de machine learning, deep learning.
- Charlas de temas aplicados como ser: ML y cambio climático, ML y healthcare, etc.

Khipu.ai 2019



- Se pueden ver los slides y los videos en <https://khipu.ai/program>
- Recomendaciones: Causality - David Lopez-Paz
- Reinforcement learning - Nando Freitas
- Machine learning fundamentals - Luciana Ferrer
- Robotics and Continuous Control - Chelsea Finn
- AlphaStar: StarCraft II using multi-agent RL - Oriol Vinyals
- Climate change and ML - Claire Monteleoni

**Muchas
Gracias!!!**

<https://github.com/data-datum/evento-r-nordeste>

